

SMART FACTORIES BEYOND TERRAIN

LOGISTICS & AUTOMATION END-TO-END SOLUTIONS





1 AND/OR Group 4

AND/OR at a Glance 6

Services 8

Global Presence 9

2 AND/OR Logistics 10

End-to-End Solutions Portfolio 12

e-S.A.T. Ecosystem Software 14

AMR Technologies 16

AMR Product Range 18

Warehousing Solutions 22

Special applications 24



At AND&OR Group, we empower our clients to maximize operational efficiency and ensure the highest reliability of their industrial processes through fully integrated, tailor made technological solutions.

Our solutions boost productivity, reduce operating costs, and deliver complete process control, ensuring consistent and high performance operations over time.

By combining advanced engineering with state of the art automation, we optimize plant performance, enhance final product quality, and guarantee full traceability across the entire production chain.

As a trusted technology partner, we design flexible and scalable solutions that evolve with your business, minimize downtime, and enable smarter, data driven decisions. The result is a more efficient, resilient, and sustainable operation, ready to meet today's challenges and tomorrow's opportunities.

AND/OR Today



Global presence in
100+ countries



5 subsidiaries across
4 continents worldwide



5 production facilities with
**over 30,000 m² of
manufacturing capacity**



A team of **300+**
professionals



150 highly skilled
technicians



4,000+ machines installed
globally



Over 40 Years of Experience

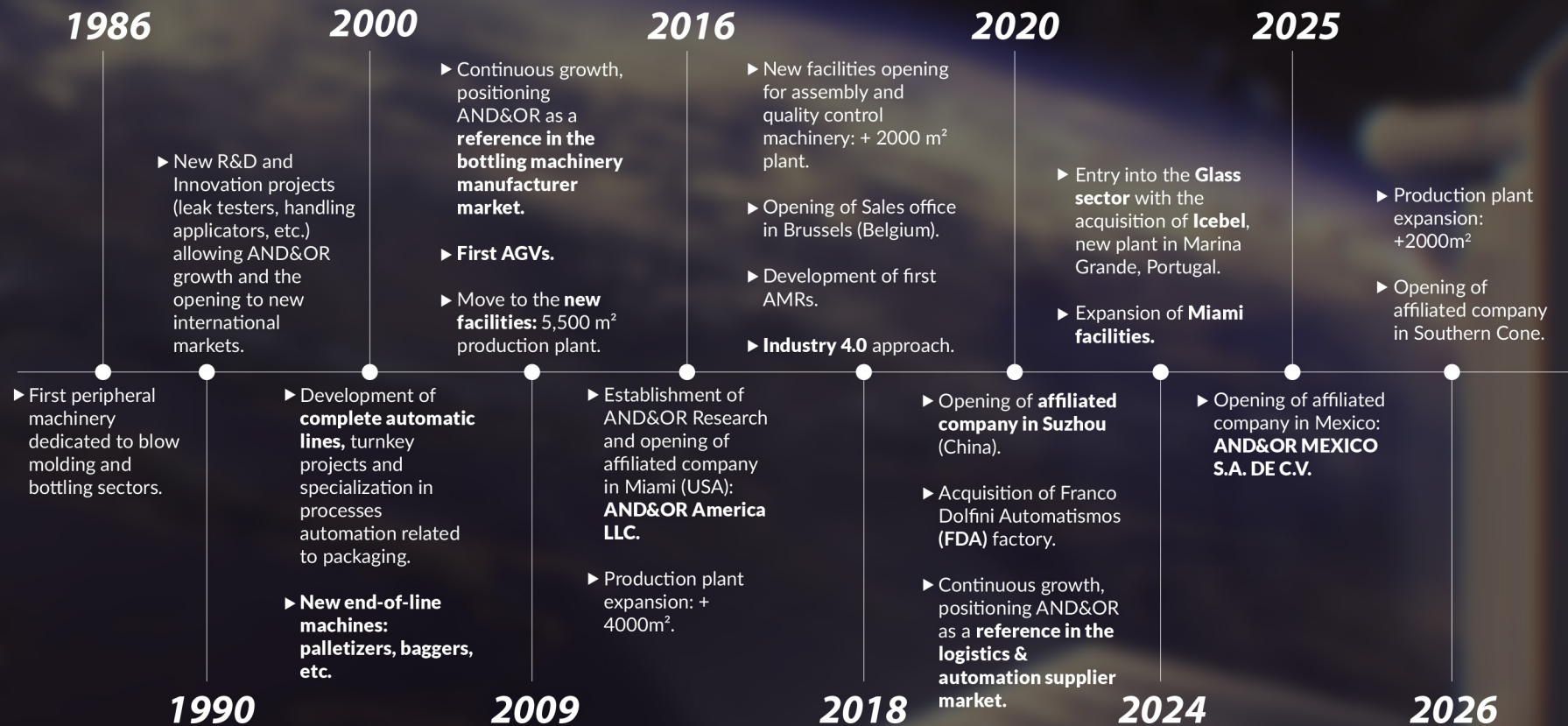

Our Collaborative Long Term Service Model is built on a continuous and proactive partnership with our clients, focused on ensuring optimal performance of their installations throughout the entire lifecycle.

Through specialized technical support, continuous maintenance, and strategic guidance, we help anticipate needs, reduce operational risks, and drive continuous system improvement.

To support this, we operate production facilities in Spain and Portugal, along with subsidiaries across the globe, including the United States, Belgium, China, Mexico, and Argentina, bringing technical service and spare parts closer to our customers.



RECOMMENDED SPARE PARTS



ANNUAL MAINTENANCE



ONSITE TECHNICAL ASSISTANCE



ONLINE TECHNICAL ASSISTANCE



TRAINING SERVICES



MACHINERY UP-GRADE



MACHINE MONITORING



STUDY/IMPROVEMENT OF PROCESSES



PARTIAL PRODUCTION MANAGEMENT/CONTROL



PROJECT MANAGEMENT



AND&OR AMERICA

Miami, US



AND&OR MEXICO

Guadalajara, Mexico



AND&OR SOUTHERN CONE

Buenos Aires, Argentina





**AND&OR
EUROPE**

Brussels, Belgium



**FDA Production
and assembly plant**

Madrid, Spain



**AND&OR
ASIA**

Suzhou, China



**ICEBEL Production
and assembly plant**

Marinha Grande, Portugal



AND&OR HQ

Seville, Spain

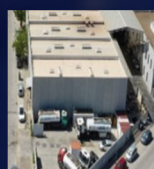

**3 AND&OR Production
and assembly plants**

Seville, Spain



SMART FACTORIES

Smart factories represent the natural evolution of the industry toward more agile, intelligent, and efficient operations in an increasingly dynamic and connected environment. In this context, AND&OR Logistics empowers companies to achieve these goals through end to end automation of logistics processes, meeting growing demands for productivity, traceability, and scalability. Leveraging our expertise in automation and autonomous mobility, we create more connected, flexible, and future ready operational environments.

END-TO-END SOLUTION

They define our comprehensive vision of intralogistics, seamlessly connecting every stage of the operational flow, from receiving and storage to internal transport and dispatch. AND&OR enables this full integration through solutions designed to adapt to existing infrastructures, optimizing processes, improving operational efficiency, and accelerating the transformation of operations into high performance intelligent ecosystems.

End-to-end Solutions Portfolio

INBOUND AREA

- 1 Trucks unloading
VOYAGER MAX
- 2 Raw materials processing
VOYAGER
- 3 Receiving area preparation
EXPLORER

PACKAGING AREA

- 4 Raw materials and tools handling
NANO PIONEER
- 5 Movement between production lines
PIONEER
- 6 End of line handling to wrapping/strapping
PIONEER

WAREHOUSING

- 7 Stocking of goods
CHALLENGER/PATHFINDER
- 8 Retrieving from warehouses
VOYAGER

OUTBOUND AREA

- 9 Expedition area preparation
VOYAGER
- 10 Trucks loading
VOYAGER MAX

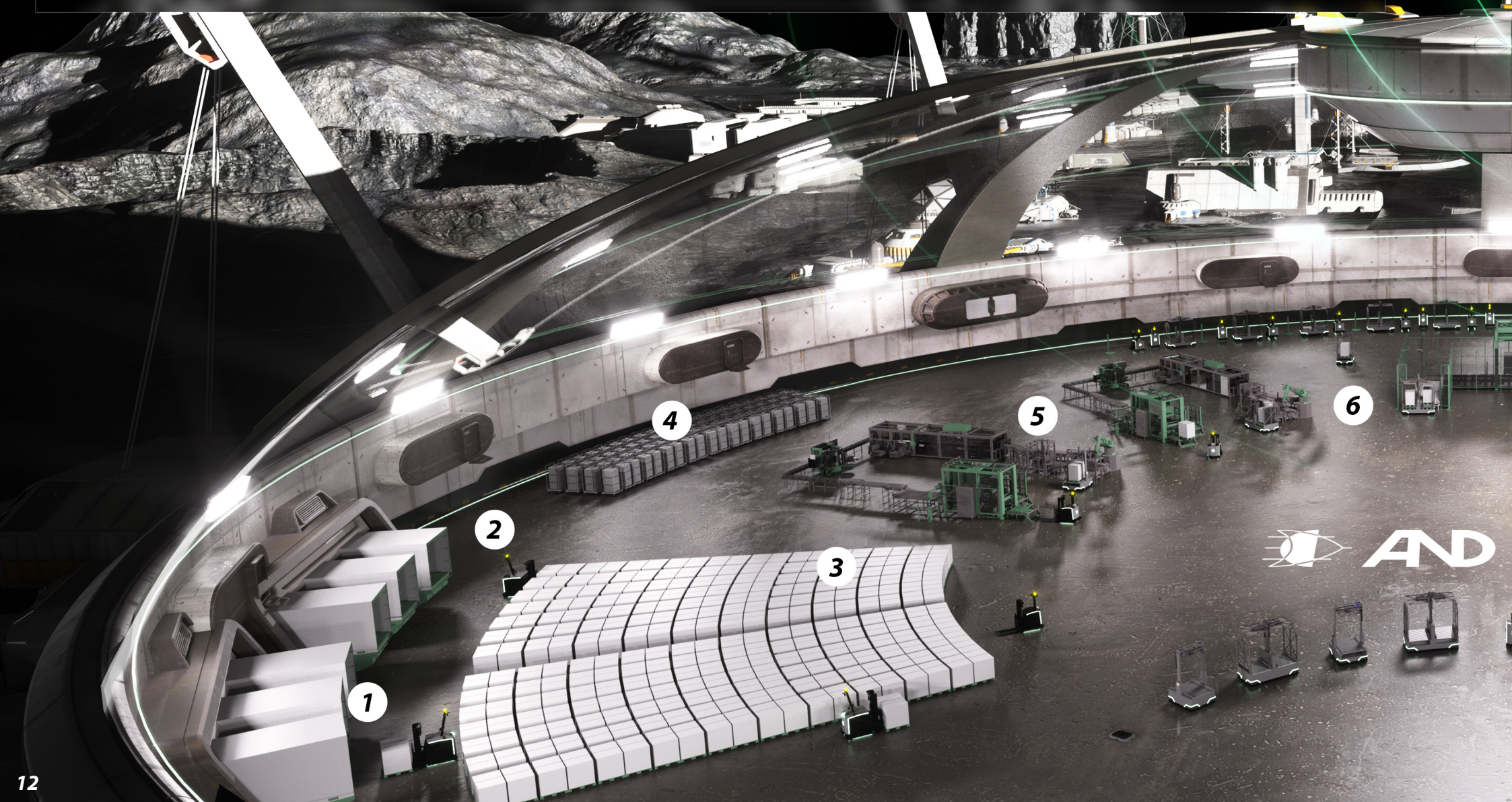

E-S.A.T.
Integrated software ecosystem
that connect the AND&OR solution
with your plant.

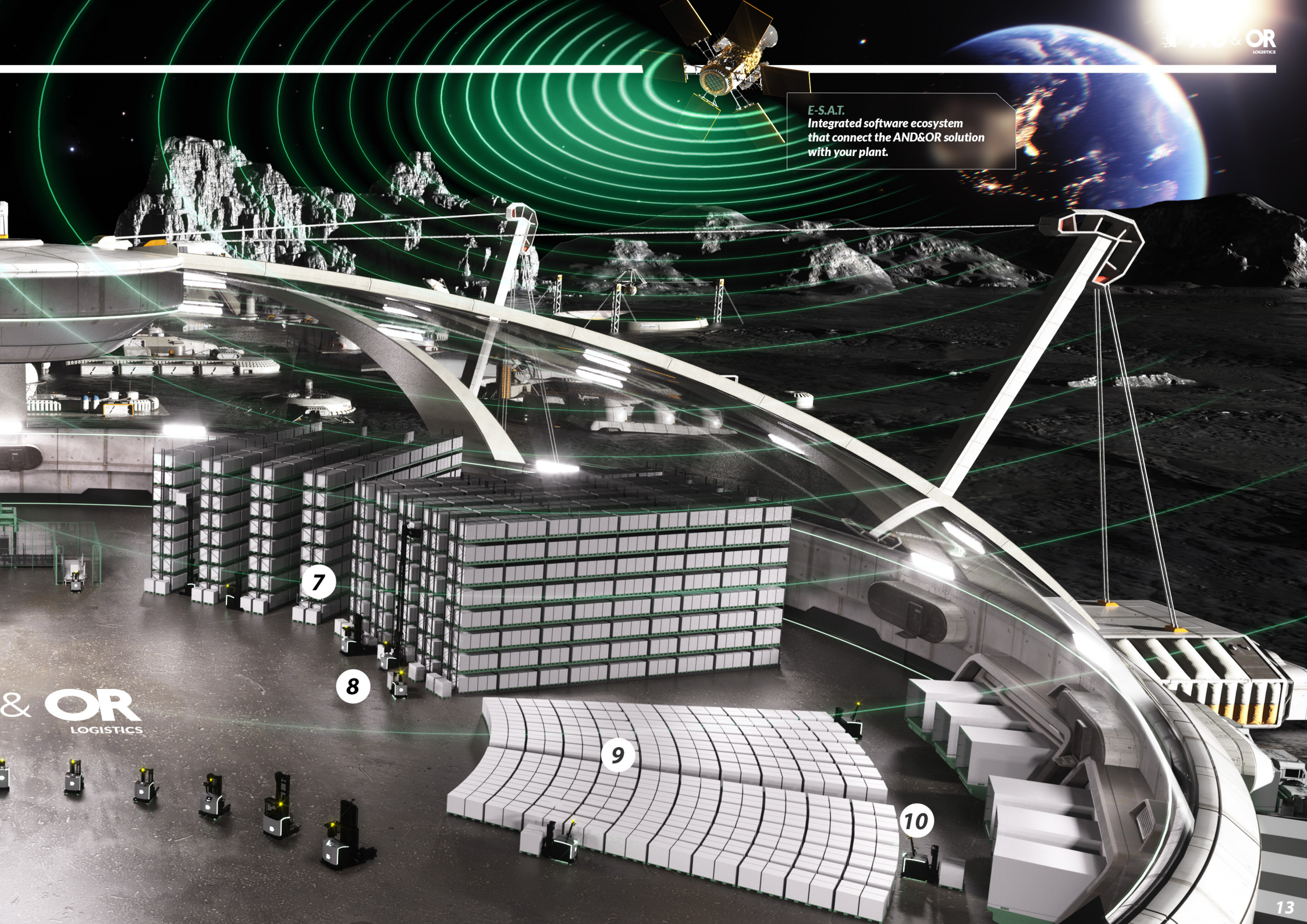

7

8

9

10

E-S.A.T.

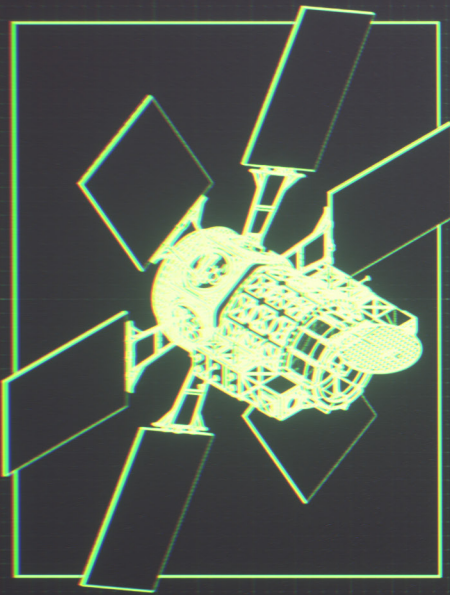

An integrated software ecosystem that connects AND/OR solutions with your plant to optimize costs, improve safety, reduce CO₂ emissions, ensure full traceability, and transform your facility into a truly Smart factory.

NEXUS

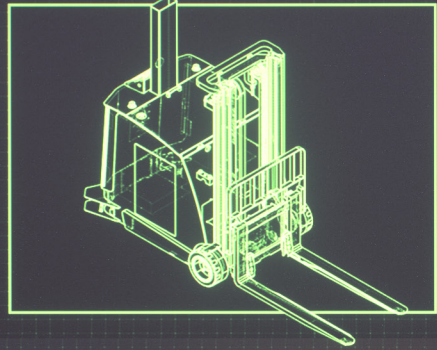

The intelligent AMR manager that commands every AMR with the fleets manager, assigning missions and directing actions according to production workflows and priorities.

TRACEABILITY

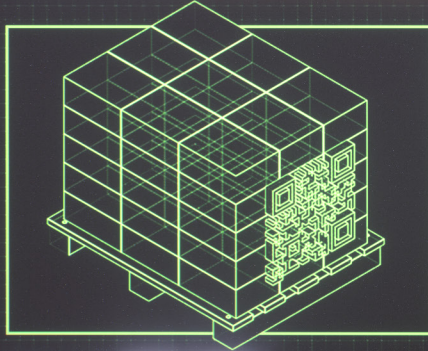

Provide real-time control of every product and movement in your plant, ensuring accuracy, compliance, and full control while minimizing errors.



FLEET MANAGEMENT

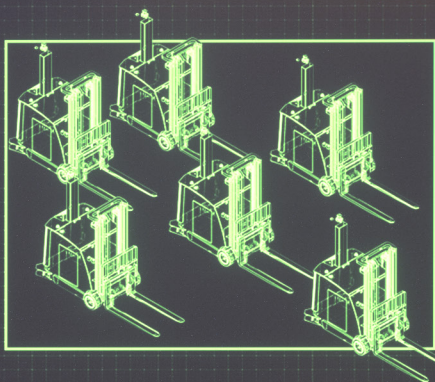

AMR fleets in real time, optimizing task allocation, traffic flow and priorities, while eliminating bottlenecks and ensuring safety. VDA 5050 compliant.

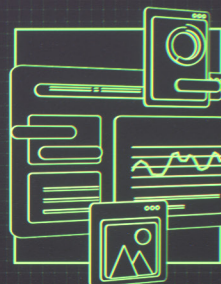

LYNX

Monitor OEE with yoy factory to provide real-time visibility and performance insights, enabling proactive issue detection and minimized downtime. Get customized reports with just one click.

WMS

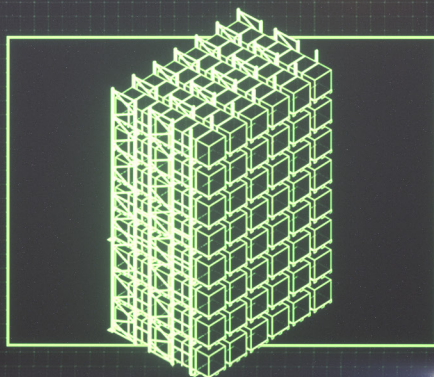

Transform your warehouse into a fully controlled, optimized and end-to-end traceable operation, driven by advanced AMR management.

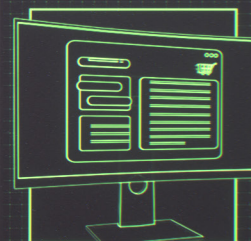

E-LIBRARY

Centralize documentation and integrate your spare parts marketplace, all within one unified platform.



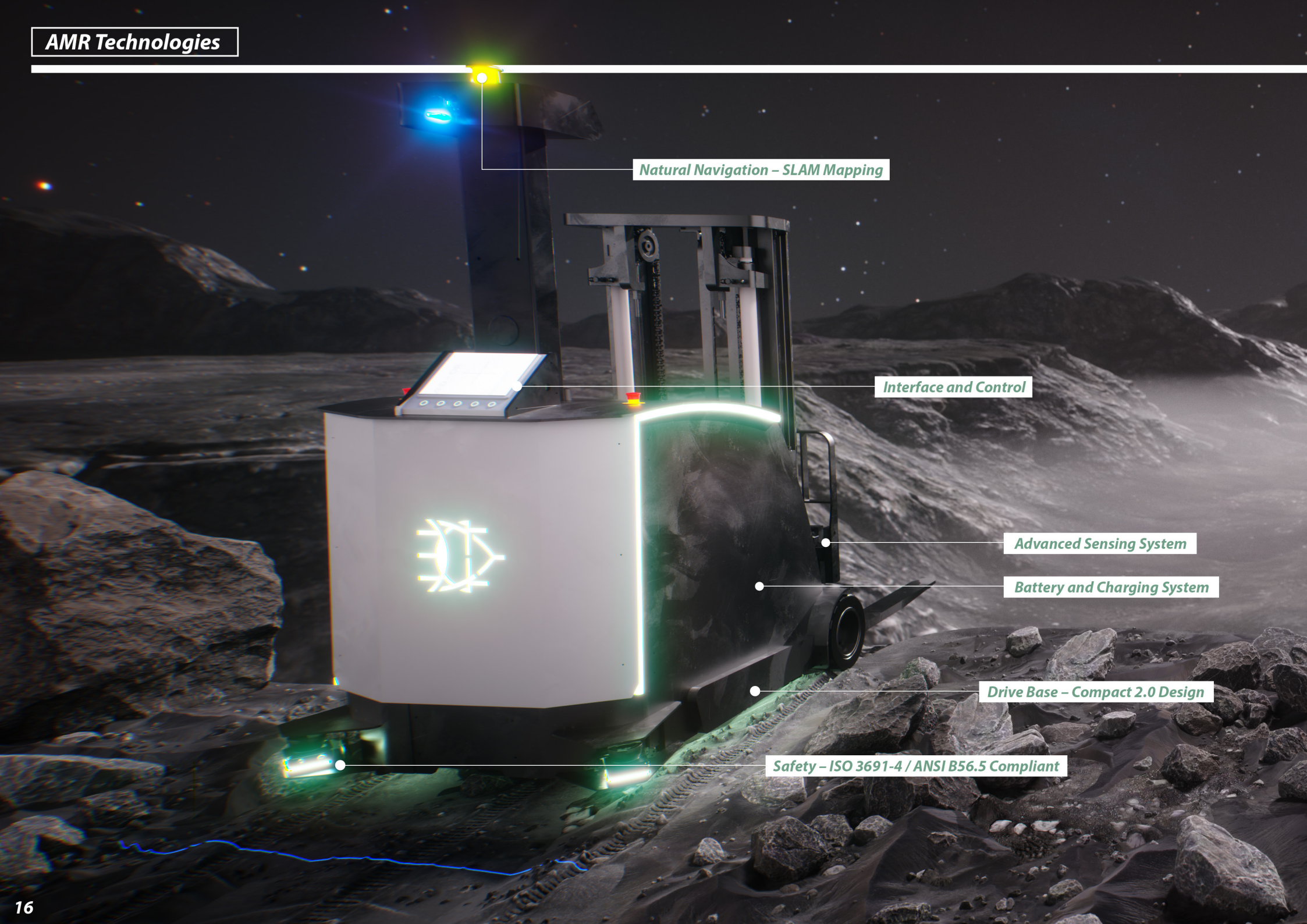

Natural Navigation – SLAM Mapping

Interface and Control

Advanced Sensing System

Battery and Charging System

Drive Base – Compact 2.0 Design

Safety – ISO 3691-4 / ANSI B56.5 Compliant

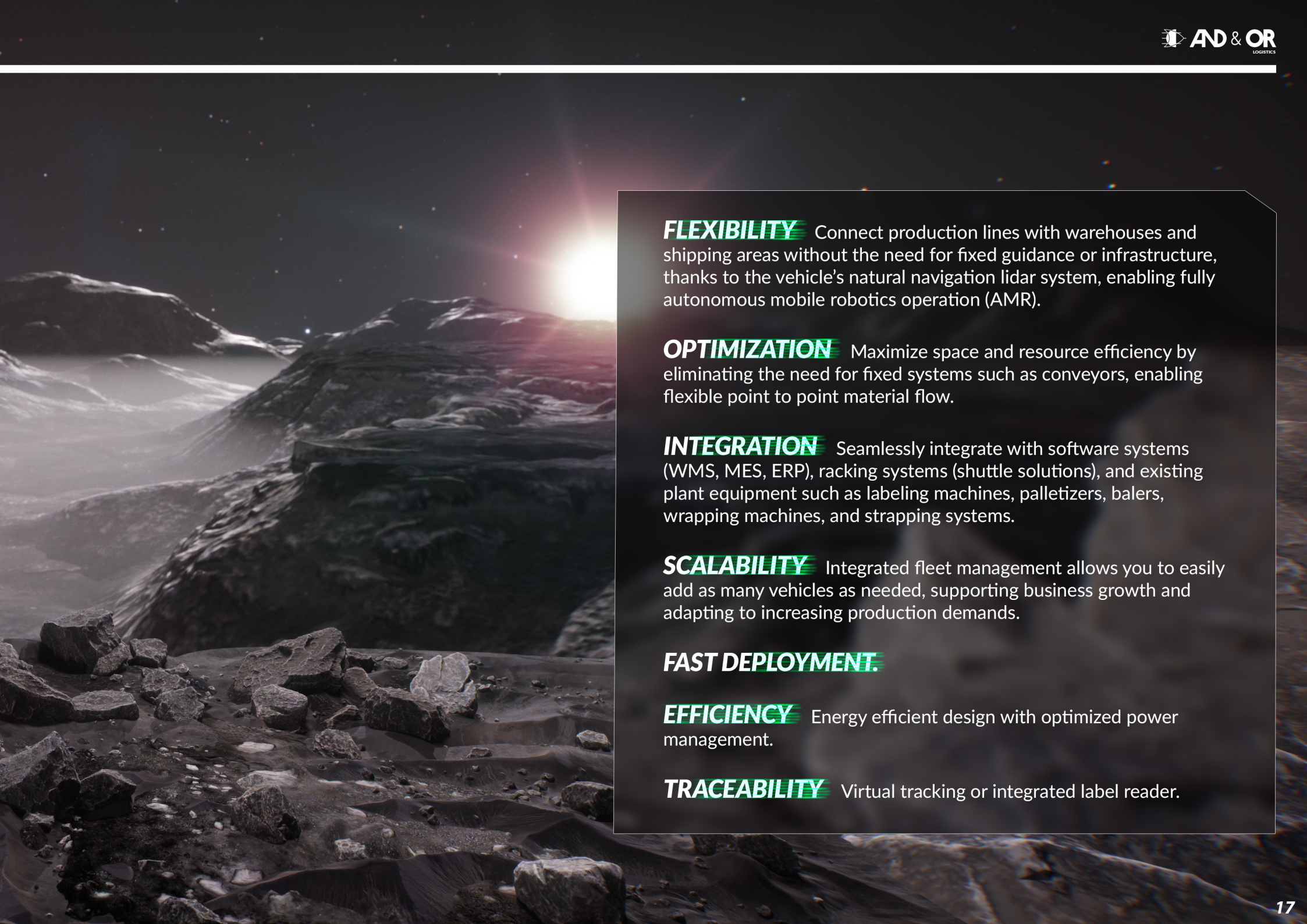

FLEXIBILITY Connect production lines with warehouses and shipping areas without the need for fixed guidance or infrastructure, thanks to the vehicle's natural navigation lidar system, enabling fully autonomous mobile robotics operation (AMR).

OPTIMIZATION Maximize space and resource efficiency by eliminating the need for fixed systems such as conveyors, enabling flexible point to point material flow.

INTEGRATION Seamlessly integrate with software systems (WMS, MES, ERP), racking systems (shuttle solutions), and existing plant equipment such as labeling machines, palletizers, balers, wrapping machines, and strapping systems.

SCALABILITY Integrated fleet management allows you to easily add as many vehicles as needed, supporting business growth and adapting to increasing production demands.

FAST DEPLOYMENT.

EFFICIENCY Energy efficient design with optimized power management.

TRACEABILITY Virtual tracking or integrated label reader.

safe

NANO PIONEER

NANO PIONEER is an ultra compact AMR designed to operate beneath racking systems or elevated structures. Its low profile architecture enables efficient handling and transport of loads in areas where other vehicles cannot operate, maximizing warehouse space utilization and supporting goods to person automation models.

type MOUSE

movement OMNIDIRECTIONAL

max load 1TN

robust

PIONEER

PIONEER is a platform based AMR designed for automated load transfer between conveyors, fixed stations, and production areas. Equipped with a lower deck for handling inputs and bulkier products, it acts as a mobile link between automated conveyors, providing greater flexibility than traditional systems and enabling dynamic, scalable layouts for loads of up to 2,000 kg.

type PLATFORM

movement OMNIDIRECTIONAL

max load 2TN

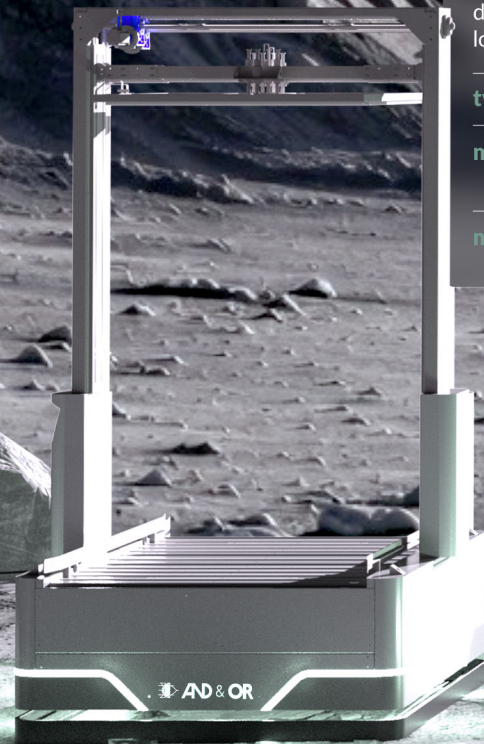
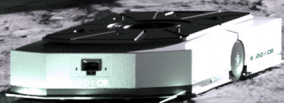

versatile

intelligent



Lorem Ipsum

PIONEER DUO

PIONEER DUO is a dual platform AMR designed to handle two loads simultaneously, enabling efficient and synchronized material handling. It is engineered for automated load transfer between conveyors, fixed stations, and production areas, and features a lower deck for handling inputs and less bulky products. Acting as a mobile link between automated conveyors, it delivers greater flexibility than traditional systems and enables dynamic, scalable layouts for loads of up to 2,000 kg.

type PLATFORM

movement OMNIDIRECTIONAL

max load 4TN

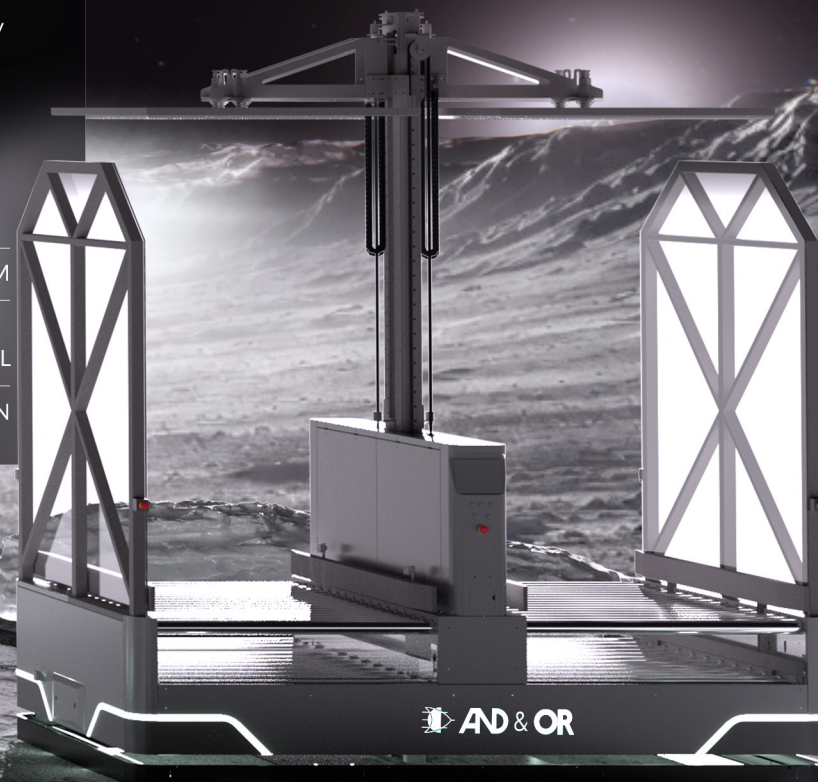
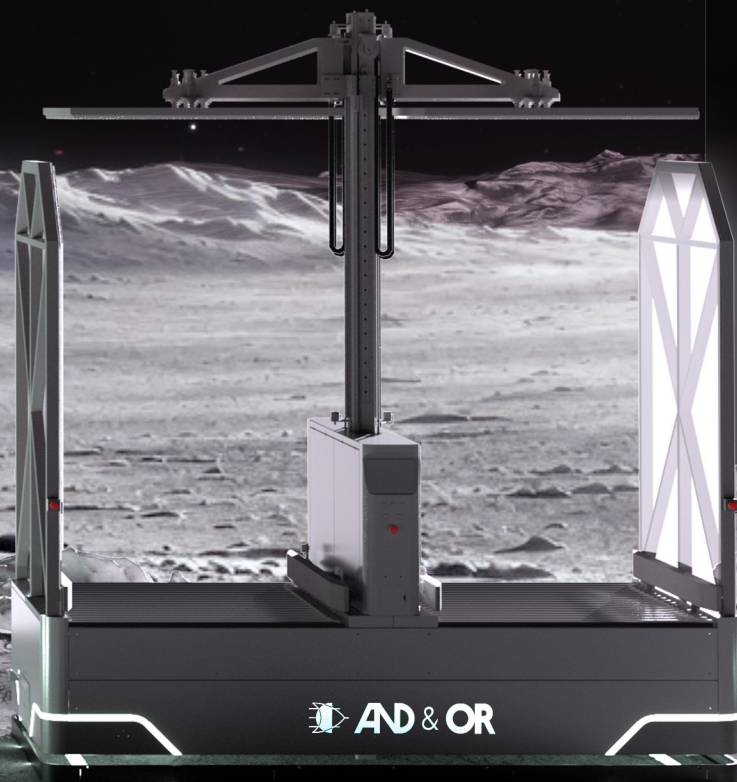

safe

EXPLORER

EXPLORER is an autonomous pallet truck designed for horizontal ground level movements. Built to automate repetitive internal flows, it provides an efficient, safe, and flexible solution for pallet transport between production, storage, and dispatch areas.

type	PALLET TRUCK
movement	BIDIRECTIONAL
max load	600 kg
max height	115mm

robust

VOYAGER

VOYAGER is a counterbalanced autonomous forklift designed to handle all types of pallets. Its versatility makes it a complete solution for mixed operations requiring flexibility, power, and universal load compatibility.

type	COUNTERBALANCED
movement	BIDIRECTIONAL
max load	2.5TN
max height	6000mm

VOYAGER MAX

VOYAGER MAX is a counterbalanced autonomous forklift optimized for loading and unloading dock operations. Designed for dynamic environments, it automates inbound and outbound processes, enhancing safety and ensuring operational continuity.

type	COUNTERBALANCED
movement	BIDIRECTIONAL
max load	6TN
max height	6000mm



versatile

intelligent



CHALLENGER

CHALLENGER is an autonomous reach truck designed for high bay warehouses with narrow aisles of approximately 3 meters. It enables vertical storage up to 8.5 meters, maximizing storage capacity without compromising precision or safety.

type	REACH TRUCK
movement	BIDIRECTIONAL
max load	3TN
max height	8500mm

CHALLENGER MAX

CHALLENGER MAX is an autonomous reach truck designed for high bay warehouses with narrow aisles of approximately 3 meters. It enables vertical storage up to 12.5 meters, maximizing storage capacity without compromising precision or safety.

type	REACH TRUCK
movement	BIDIRECTIONAL
max load	2TN
max height	12500mm

PATHFINDER

PATHFINDER is a trilateral AMR designed to operate in ultra narrow aisles of up to 1.5 meters, maximizing warehouse density and efficiency. Its trilateral head enables lateral fork movement without turning the vehicle, eliminating unnecessary.

type	VNA (Very Narrow Aisle)
movement	BIDIRECTIONAL
max load	1.6TN
max height	14200mm

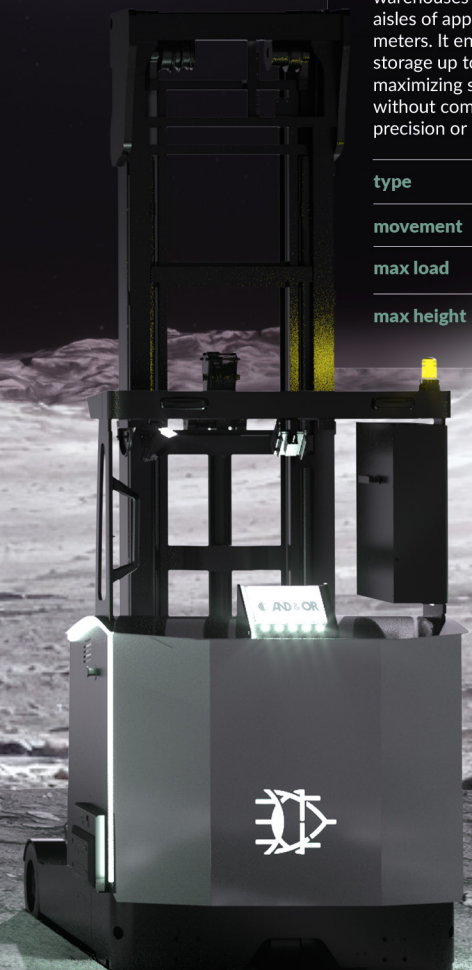
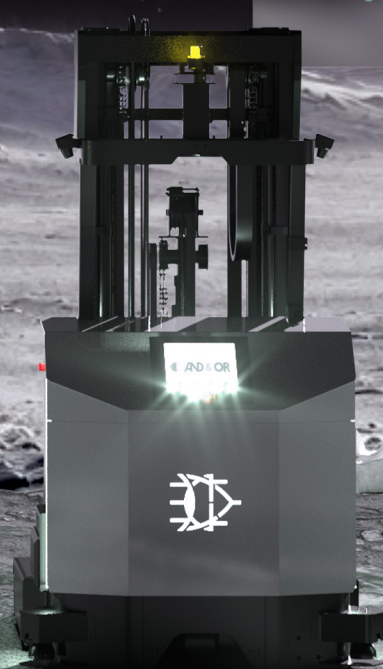

Selective Pallet Racking

Overview

A pallet storage system that provides direct and individual access to each load unit. It is the most versatile and widely used solution in logistics and industrial warehouses.

Pallets are stored on horizontal beams supported by vertical frames. Each pallet occupies an independent position and can be accessed using a front or reach truck.

Ideal Applications

- Warehouses with high turnover and a wide range of SKUs.
- Operations requiring immediate access to any pallet.
- Distribution centers and 3PL logistics.

Key Benefits

- Direct access to 100 percent of pallets.
- High flexibility for changing SKUs.
- Easy installation and reconfiguration.
- Compatible with multiple types of forklifts.



Drive-In Compact Racking

Overview

A high density storage system where forklifts enter the structure to place pallets on lateral rails.

Pallets are stored in depth on continuous rails. Loading and unloading are carried out from the same aisle, operating under a LIFO system.

Ideal Applications

- Homogeneous products.
- Low number of SKUs.
- Cold storage environments.
- Safety stock.

Key Benefits

- Maximum space utilization
- Reduced number of aisles
- High storage density

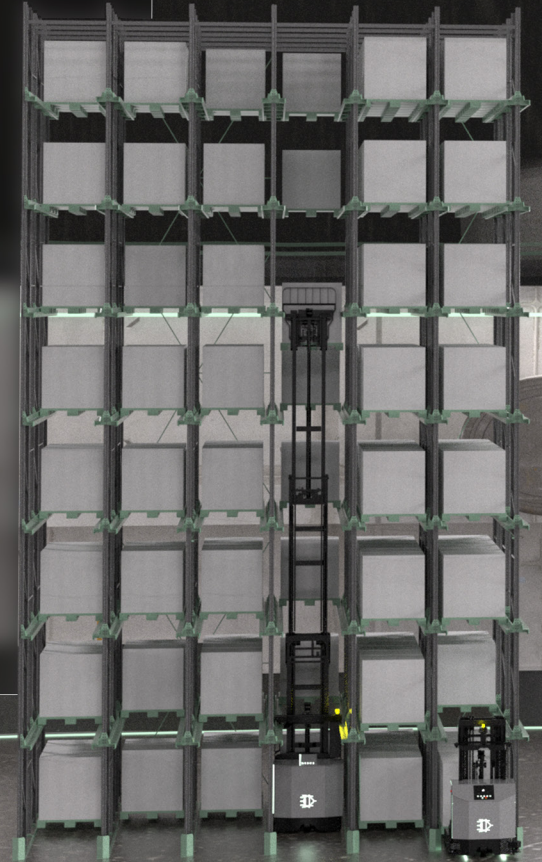

Semi-Automated Shuttle Racking

Overview

A high density compact system that incorporates a motorized shuttle to automatically transport pallets within storage lanes.

The forklift places the pallet at the lane entrance, and the shuttle moves it automatically to the next available position. The system can operate in LIFO or FIFO depending on configuration.

Ideal Applications

- High turnover with accumulation by SKU.
- Cold storage environments.
- Operations requiring increased safety and reduced product damage.

Key Benefits

- Higher density than selective racking.
- Reduced operational times.
- Increased safety as forklifts do not enter the structure.
- Reduced structural damage

PLS Dynamic Racking (Pallet Live Storage)

Overview

A gravity driven dynamic system where pallets move automatically on rollers from the loading point to the picking or unloading point.

Pallets are loaded from one side of the lane and move along a slight incline toward the opposite end.

- **FIFO configuration:** loading on one side and unloading on the other.
- **LIFO configuration:** loading and unloading from the same side.

Ideal Applications

- Perishable goods.
- High turnover operations.
- Food and pharmaceutical industries.
- Order picking.

Key Benefits

- Automatic FIFO management.
- Reduced travel distances.
- High operational efficiency.
- Clear separation between loading and unloading (FIFO).



RETORTS

Our AMRs automate the transport of heavy trays containing food pouches to retorts, ensuring smooth, stable, and precise movement. This minimizes product damage while eliminating manual handling, enhancing safety and ensuring continuous, reliable operations.



FILM ROLLS

Our AMRs handle heavy, long plastic film rolls using specially designed cylindrical clamps, ensuring safe, stable, and fully automated intralogistics transport.



PREFORMS

Our AMRs automatically handle containers of preforms or injection molded parts in cartons or metal and plastic gaylords. They feed empty containers into soft drop systems, remove full containers, and can also transport finished goods to the warehouse, enabling floor storage and multi level stacking.





AVENIDA DE EUROPA, 6. PARQUE EMPRESARIAL EL LIMÓN · 41928 PALOMARES DEL RÍO – SEVILLA, SPAIN

WWW.ANDYOR.COM | (+34) 95 477 92 00